

110 SBFR, 130 SBFR Inflation Machine

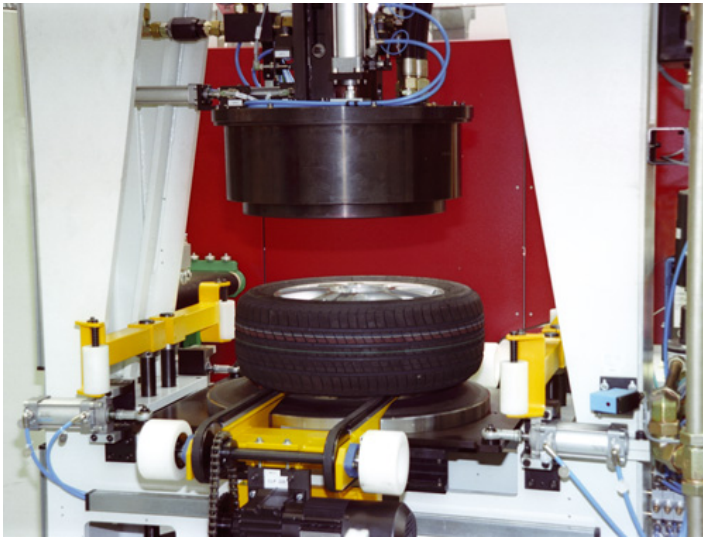

- Inflation bell without sealing ring and other wearing parts
- Extended working radius (up to 6 wheels) with telescope design
- Applicable with any rim configuration, also light alloy rims with edgeless, spoke design
- No loads acting on the rims
- Automatic sequence and mixed operation
- Linking with production lines

Range of application

Inflation of tubeless passenger vehicle tires in normal, low profile and super low profile design. Suitable for tires mounted onto steel or light alloy rims of various dimensions.

Application of the machine in series production.

Simple integration into existing or new lines, with a preceding tiremounting machine, and succeeding tire-bead stabilization machine and wheel balancing machine.

Design

Single-station machine with fully automatic sequence, loading and unloading of the machine by a fully automatic conveyor system.

Double belt conveyor on welded stand with lifting function, inflation table with flat seals, centering device, inflation bell and hydro-pneumatic lowering and locking equipment installed.

Sequence of operations

- Automatic transfer of the assembled wheel from the feeder belt into the inflation station by the double-belt conveyor
- Automatic sequence: Lower the transporter and lay the wheel onto the inflation table
- Center the rim and tire, lift the wheel and set onto the table.
- Lower the inflation bell onto the tire and inflate to the required pressure
- Lift the inflation bell
- Automatic transfer of the inflated wheel in the direction of the balancing machine

110 SBFR, 130 SBFR Inflation Machine



By control of the inflation bell a high inflation accuracy and good seating of the upper tire bead is achieved. The lowering depth of the bell is automatically adapted depending on the individual properties of the wheel combination through a specific, empirically-determined inflation program. The inflation pressure program is selectable manually or automatically through the program control.

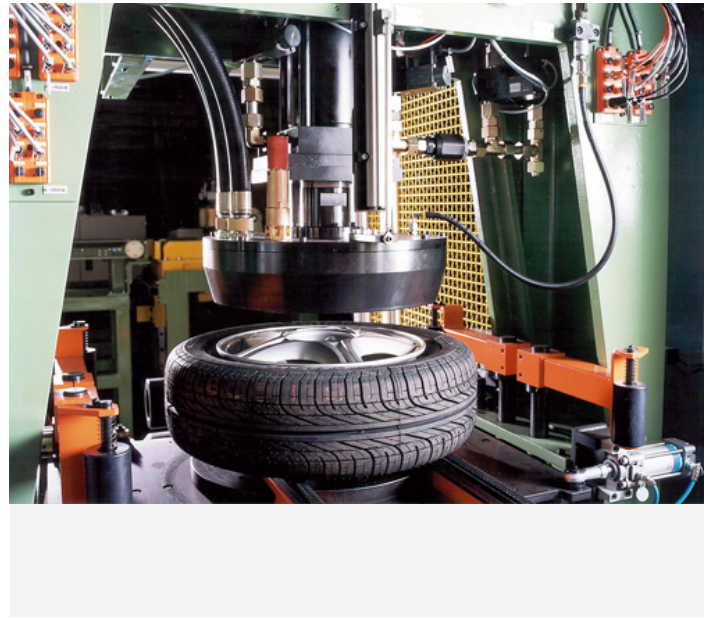

The special construction of the patented inflation bell does away with the normal rim-sealing arrangement and is therefore practically wear-free. In addition light-alloy rims with edgeless spoke design can be inflated without problems in mixed operation, and machine operation is independent of the rim design. Due to the absence of the counter-force exerted by the rim sealing ring used in conventional systems, no loads are acting on the rim. This is an important aspect in the case of thin-walled rims with high sensitivity to side pressure.

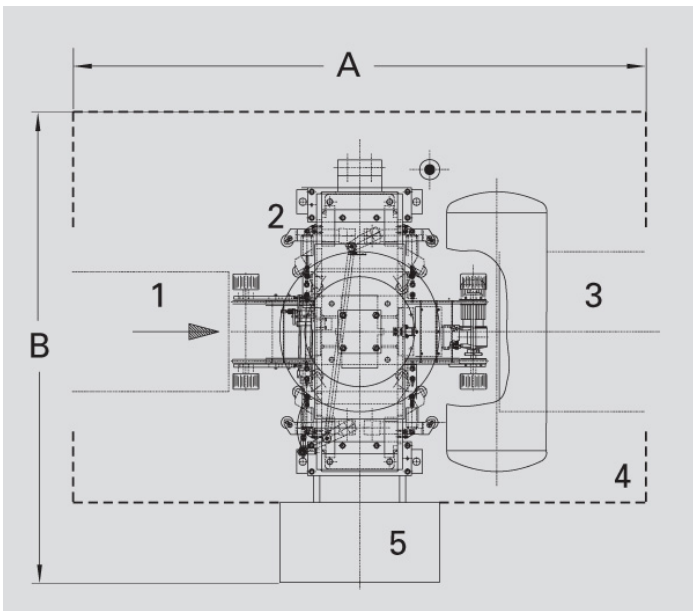

1 Wheel feed 2 Filling station 3 Wheel outlet 4 Protective grill 5 Switch cabinet

Plan view (non-binding example: dimensions of the switch cabinet depend on the relevant application)

110 SBFR, 130 SBFR Inflation Machine

Technical data at a glance		110 SBFR	130 SBFR
Fully automatic sequence of operations		•	•
Complete wheel			
Weight, max.	[kg]	50	50
Overall width	[mm]	120 - 350	120 - 350
Outerside diameter, tire-	[mm]	560 - 900	560 - 900
Diameter, standart wheel	[Zoll]	13-15 / 14-16 / 15-17	13-18 / 14-19 / 15-20
Diameter, emergency wheel	[Zoll]	a. A.	a. A.
Bead width	[Zoll]	3,5 - 12,0	3,5 - 12,0
Machine			
Width A	[mm]	1300	1300
Depth B	[mm]	1955	1955
Height C	[mm]	3100	3100
Inflation tolerance	[kPa]	10 - 50	10 - 50
Cycle time, max.	[s]	7	09-Nov
Production rate	[St./h]	510	450 / 325
Air pressure	[kPa]	600 - 1000	600 - 1000
Air consumption	[m ³ /h]	400	300 - 400
Power supply	[V]	400	400
Power consumption	[kVA]	10	10
	Order No.	R0600100.01	R0600400.01
	Order No.	R0600101.01	R0600401.01
Sound absorbing equipment	Order No.	R0600102.01	R0600402.01
Infeed conveyor	Order No.	R0600103.01	R0600403.01
Intermediate conveyor	Order No.	R0600104.01	R0600404.01

2) Data non-binding, depends on the respective equipment supplied

3) Main configuration: 3 / PEN AC 50Hz 400 V +6 / -10%

4) Transfer of tire and wheel data to the line

5) Depending on the required inflation pressure